

MGate™ MB3170/3270

1 and 2-port advanced serial-to-Ethernet Modbus gateways



- > Configuration is exceptionally easy
- > Slave mode supports 16 TCP masters and up to 31 or 62 serial slaves at the same time
- > Master mode supports 32 TCP slaves at the same time
- > Emergency request tunnels ensure QoS control
- > Serial redirector function provided
- > Embedded Modbus protocol analyzer
- > Redundant dual DC power inputs
- > Built-in Ethernet cascading for easy wiring



Overview

The MB3170 and MB3270 are advanced Modbus gateways that provide maximum flexibility for integrating industrial Modbus networks of all types and sizes. They are designed to integrate Modbus TCP, ASCII, and RTU devices in almost any master and slave combination, including serial master to serial slave, or simultaneous serial and

Ethernet masters. A special priority control feature allows urgent commands to obtain an immediate response. All models are ruggedly constructed, are DIN-rail mountable, and offer built-in optical isolation for serial signals as an option.

Integrate TCP Masters without Altering the Modbus RTU/ASCII Network or Software

The MB3270 can integrate Modbus TCP with Modbus RTU/ASCII, without modifying the existing Modbus RTU/ASCII architecture or software. With the serial redirector function, a serial master can

maintain direct access to serial slave devices through a specially mapped serial port. This allows the serial and TCP masters to access serial slaves simultaneously.

Cascade Ethernet Ports for Easy Wiring

Advanced models of the MGate™ MB3000 series have two Ethernet ports to make network wiring easier. Dual Ethernet ports allow users to string multiple Modbus gateways together using standard RJ45 Ethernet cables, eliminating the need for a separate Ethernet switch.

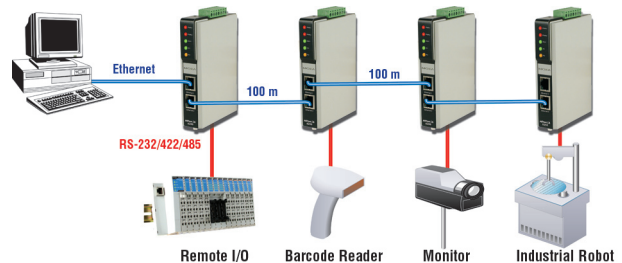

Redundant Power Inputs

Advanced models of the MB3000 series have dual power inputs for greater reliability. The power inputs allow simultaneous connections to two live DC power sources, so that continuous operation is provided

even if one power source fails. The higher level of reliability makes these advanced Modbus gateways ideal for demanding industrial applications.

Warning by Relay Output

A relay output is provided for the Ethernet link and power input status. The relay output gives maintenance engineers an additional tool for

troubleshooting and maintenance.

Priority Control for Urgent Commands (Patented)

As Modbus networks increase in size and complexity, the lag time between commands and responses becomes a major concern. Advanced models of the MB3000 series provide a priority control function for urgent commands, allowing users to force certain commands to get an immediate response. Depending on your system's requirements, different methods are available to define which commands receive priority.

Patent Numbers: (US/TW)

US7,743,192 B2 / I332618

US7,725,635 B2 / I321007

Specifications

Ethernet Interface

Number of Ports: 2 (1 IP)

Speed: 10/100 Mbps, Auto MDI/MDIX

Connector: 8-pin RJ45

Magnetic Isolation Protection: 1.5 KV built-in

Serial Interface

Number of Ports:

MB3170/3170I: 1

MB3270/3270I: 2

Serial Standards: RS-232/422/485, software selectable

Connectors:

MB3170/3170I: DB9 male for RS-232, Terminal block for RS-422/485

MB3270/3270I: DB9 male x 2

ESD Protection: 15 KV for all signals

RS-485 Data Direction Control: ADDC® (automatic data direction control)

Pull High/Low Resistor for RS-485: 1 K Ω , 150 K Ω

Terminator for RS-485: 120 Ω

Serial Communication Parameters

Data Bits: 7, 8

Stop Bits: 1, 2

Parity: None, Even, Odd, Space, Mark

Flow Control: RTS/CTS, DTR/DSR (RS-232 only)

Baudrate: 50 bps to 921.6 Kbps

Serial Signals

RS-232: TxD, RxD, RTS, CTS, DTR, DSR, DCD, GND

RS-422: Tx+, Tx-, Rx+, Rx-, GND

RS-485-4w: Tx+, Tx-, Rx+, Rx-, GND

RS-485-2w: Data+, Data-, GND

Software

Operation Modes: RTU Slave, RTU Master, ASCII Slave, ASCII Master

Configuration Options: Web Console, Serial Console, Telnet Console, Windows Utility

Utilities: MGate Manager for Windows 98/ME/NT/2000, Windows XP/2003/Vista/2008/7 x86/x64

Multi-master and Multi-drop:

Master mode: 32 TCP slaves

Slave mode: 16 TCP masters (request queue 32-deep for each master)

Bonus Features: Smart Routing, Serial Redirection, Priority Control

Physical Characteristics

Housing: Plastic

Weight:

MGate MB3170: 360 g

MGate MB3270: 380 g

Dimensions:

Without ears: 29 x 89.2 x 118.5 mm (1.14 x 3.51 x 4.67 in)

With ears extended: 29 x 89.2 x 124.5 mm (1.14 x 3.51 x 4.90 in)

Environmental Limits

Operating Temperature:

Standard Models: 0 to 55°C (32 to 131°F)

Wide Temp. Models: -40 to 75°C (-40 to 167°F)

Storage Temperature: -40 to 85°C (-40 to 185°F)

Ambient Relative Humidity: 5 to 95% (non-condensing)

Power Requirements

Input Voltage: 12 to 48 VDC

Power Connector: Terminal block

Power Consumption:

MGate M3170: 435 mA (max.)

MGate M3170I: 555 mA (max.)

MGate M3270: 435 mA (max.)

MGate M3270I: 510 mA (max.)

Standards and Certifications

Safety: UL 60950-1, EN 60950-1

Hazardous Location:

UL/cUL Class I Division 2 Groups A/B/C/D,

ATEX Zone 2

EMC: CE, FCC

EMI: EN 55022 Class A, FCC Part 15 Subpart B Class A

EMS:

EN 55024,

EN 61000-4-2 (ESD) Level 3,

EN 61000-4-3 (RS) Level 3,

EN 61000-4-4 (EFT) Level 4,

EN 61000-4-5 (Surge) Level 3,

EN 61000-4-6 (CS) Level 3,

EN 61000-4-8,

EN 61000-4-11,

EN 61000-4-12

Marine: DNV

Shock: IEC 60068-2-27

Freefall: IEC 60068-2-23

Vibration: IEC 60068-2-6

Reliability

MTBF (mean time between failures):

MGate M3170: 210,794 hrs

MGate M3270: 125,234 hrs

Warranty

Warranty Period: 5 years

Details: See www.moxa.com/warranty

Dimensions

Unit: mm (inch)

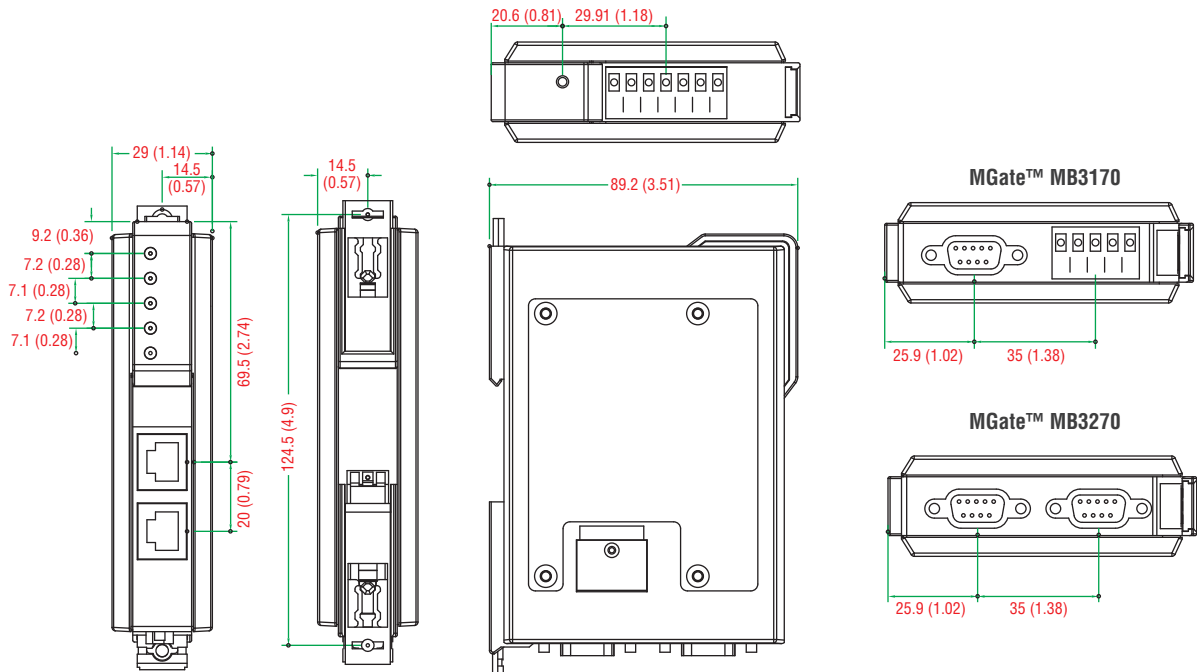

Ordering Information

Available Models

- MGate MB3170:** 1-port advanced Modbus gateway, 0 to 55°C operating temperature
- MGate MB3170I:** 1-port advanced Modbus gateway with 2 KV isolation, 0 to 55°C operating temperature
- MGate MB3270:** 2-port advanced Modbus gateway, 0 to 55°C operating temperature
- MGate MB3270I:** 2-port advanced Modbus gateway with 2 KV isolation, 0 to 55°C operating temperature
- MGate MB3170-T:** 1-port advanced Modbus gateway, -40 to 75°C operating temperature
- MGate MB3170I-T:** 1-port advanced Modbus gateway with 2 KV isolation, -40 to 75°C operating temperature
- MGate MB3270-T:** 2-port advanced Modbus gateway, -40 to 75°C operating temperature
- MGate MB3270I-T:** 2-port advanced Modbus gateway with 2 KV isolation, -40 to 75°C operating temperature

Optional Accessories (can be purchased separately)

- DR-45-24:** 24 VDC DIN-rail power supply (2 A @ 45 W) with universal 85 to 264 VAC input
- DR-75-24:** 24 VDC DIN-rail power supply (3.2 A @ 75 W) with universal 85 to 264 VAC input
- DR-120-24:** 24 VDC DIN-rail power supply (5 A @ 120 W) with switch for choosing 88 to 132 VAC, or 176 to 264 VAC input

Package Checklist

- 1 MGate MB3170 or MB3170I or MB3270 or MB3270I modbus gateway
- Documentation and software CD
- Quick installation guide (printed)
- Warranty card